

SIPMOS® Power Transistor
Features

- N channel
- Enhancement mode
- Avalanche rated
- dv/dt rated
- 175°C operating temperature

Product Summary

Drain source voltage	V_{DS}	30	V
Drain-Source on-state resistance	$R_{DS(on)}$	0.006	Ω
Continuous drain current	I_D	80	A

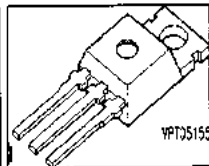
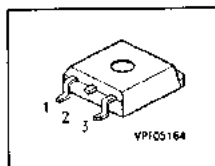

Type	Package	Ordering Code	Packaging
SPP80N03	P-TO220-3-1	Q67040-S4734-A2	Tube
SPB80N03	P-TO263-3-2	Q67040-S4734-A3	Tube and Reel

Pin 1	Pin 2	Pin 3
G	D	S

Maximum Ratings, at $T_j = 25^\circ\text{C}$, unless otherwise specified

Parameter	Symbol	Value	Unit
Continuous drain current $T_C = 25^\circ\text{C}$, 1) $T_C = 100^\circ\text{C}$	I_D	80 80	A
Pulsed drain current $T_C = 25^\circ\text{C}$	I_{Dpulse}	320	
Avalanche energy, single pulse $I_D = 80\text{ A}$, $V_{DD} = 25\text{ V}$, $R_{GS} = 25\ \Omega$	E_{AS}	700	mJ
Avalanche energy, periodic limited by T_{jmax}	E_{AR}	30	
Reverse diode dv/dt $I_S = 80\text{ A}$, $V_{DS} = 24\text{ V}$, $di/dt = 200\text{ A}/\mu\text{s}$, $T_{jmax} = 175^\circ\text{C}$	dv/dt	6	kV/ μs
Gate source voltage	V_{GS}	± 20	V
Power dissipation $T_C = 25^\circ\text{C}$	P_{tot}	300	W
Operating and storage temperature	T_j, T_{stg}	-55... +175	$^\circ\text{C}$
IEC climatic category; DIN IEC 68-1		55/175/56	

■ 8235605 0133758 T71 ■

Thermal Characteristics

Parameter	Symbol	Values			Unit
		min.	typ.	max.	
Characteristics					
Thermal resistance, junction - case	R_{thJC}	-	-	0.5	KW
Thermal resistance, junction - ambient, leded	R_{thJA}	-	-	62	
SMD version, device on PCB: @ min. footprint @ 6 cm ² cooling area ²⁾	R_{thJA}	-	-	62 40	

Electrical Characteristics, at $T_j = 25\text{ }^\circ\text{C}$, unless otherwise specified

Parameter	Symbol	Values			Unit
		min.	typ.	max.	
Static Characteristics					
Drain- source breakdown voltage $V_{GS} = 0\text{ V}$, $I_D = 0.25\text{ mA}$, $T_j = 25\text{ }^\circ\text{C}$	$V_{(BR)DSS}$	30	-	-	V
Gate threshold voltage, $V_{GS} = V_{DS}$ $I_D = 240\text{ }\mu\text{A}$	$V_{GS(th)}$	2.1	3	4	
Zero gate voltage drain current $V_{DS} = 30\text{ V}$, $V_{GS} = 0\text{ V}$, $T_j = 25\text{ }^\circ\text{C}$ $V_{DS} = 30\text{ V}$, $V_{GS} = 0\text{ V}$, $T_j = 150\text{ }^\circ\text{C}$	I_{DSS}	-	0.1	1 100	μA
Gate-source leakage current $V_{GS} = 20\text{ V}$, $V_{DS} = 0\text{ V}$	I_{GSS}	-	10	100	nA
Drain-Source on-state resistance $V_{GS} = 10\text{ V}$, $I_D = 80\text{ A}$	$R_{DS(on)}$	-	0.0038	0.006	Ω

¹current limited by bond wire

² Device on 40mm*40mm*1.5mm epoxy PCB FR4 with 6 cm² (one layer, 70 μm thick) copper area for drain connection. PCB is vertical without blown air.

8235605 0133759 908

Electrical Characteristics, at $T_j = 25\text{ }^\circ\text{C}$, unless otherwise specified

Parameter	Symbol	Values			Unit
		min.	typ.	max.	
Dynamic Characteristics					
Transconductance $V_{DS} \geq 2 \cdot I_D \cdot R_{DS(on)max}$, $I_D = 80\text{ A}$	g_{fs}	30	93	-	S
Input capacitance $V_{GS} = 0\text{ V}$, $V_{DS} = 25\text{ V}$, $f = 1\text{ MHz}$	C_{iss}	-	3970	5000	pF
Output capacitance $V_{GS} = 0\text{ V}$, $V_{DS} = 25\text{ V}$, $f = 1\text{ MHz}$	C_{oss}	-	1920	2500	
Reverse transfer capacitance $V_{GS} = 0\text{ V}$, $V_{DS} = 25\text{ V}$, $f = 1\text{ MHz}$	C_{rss}	-	775	1000	
Turn-on delay time $V_{DD} = 15\text{ V}$, $V_{GS} = 10\text{ V}$, $I_D = 80\text{ A}$, $R_G = 2.5\ \Omega$	$t_{d(on)}$	-	22	33	
Rise time $V_{DD} = 15\text{ V}$, $V_{GS} = 10\text{ V}$, $I_D = 80\text{ A}$, $R_G = 2.5\ \Omega$	t_r	-	25	38	
Turn-off delay time $V_{DD} = 15\text{ V}$, $V_{GS} = 10\text{ V}$, $I_D = 80\text{ A}$, $R_G = 2.5\ \Omega$	$t_{d(off)}$	-	55	85	
Fall time $V_{DD} = 15\text{ V}$, $V_{GS} = 10\text{ V}$, $I_D = 80\text{ A}$, $R_G = 2.5\ \Omega$	t_f	-	40	60	

■ 8235605 0133760 62T ■

Electrical Characteristics, at $T_j = 25\text{ }^\circ\text{C}$, unless otherwise specified

Parameter	Symbol	Values			Unit
		min.	typ.	max.	
Dynamic Characteristics					
Gate to source charge $V_{DD} = 24\text{ V}$, $I_D = 80\text{ A}$	Q_{gs}	-	20	30	nC
Gate to drain charge $V_{DD} = 24\text{ V}$, $I_D = 80\text{ A}$	Q_{gd}	-	51	76.5	
Gate charge total $V_{DD} = 24\text{ V}$, $I_D = 80\text{ A}$, $V_{GS} = 0\text{ to }10\text{ V}$	Q_g	-	112	175	
Gate plateau voltage $V_{DD} = 24\text{ V}$, $I_D = 80\text{ A}$	$V_{(\text{plateau})}$	-	4.7	-	V

Reverse Diode

Inverse diode continuous forward current $T_C = 25\text{ }^\circ\text{C}$	I_S	-	-	80	A
Inverse diode direct current, pulsed $T_C = 25\text{ }^\circ\text{C}$	I_{SM}	-	-	320	
Inverse diode forward voltage $V_{GS} = 0\text{ V}$, $I_F = 160\text{ A}$	V_{SD}	-	1.1	1.7	V
Reverse recovery time $V_R = 15\text{ V}$, $I_F = I_S$, $dI_F/dt = 100\text{ A}/\mu\text{s}$	t_{rr}	-	60	90	ns
Reverse recovery charge $V_R = 15\text{ V}$, $I_F = I_S$, $dI_F/dt = 100\text{ A}/\mu\text{s}$	Q_{rr}	-	0.06	0.09	μC

■ 8235605 0133761 566 ■

Power Dissipation

$P_{tot} = f(T_C)$

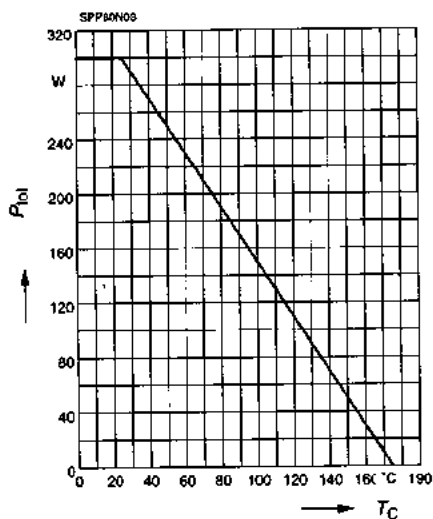

Drain current

$I_D = f(T_C)$

parameter: $V_{GS} \geq 10\text{ V}$

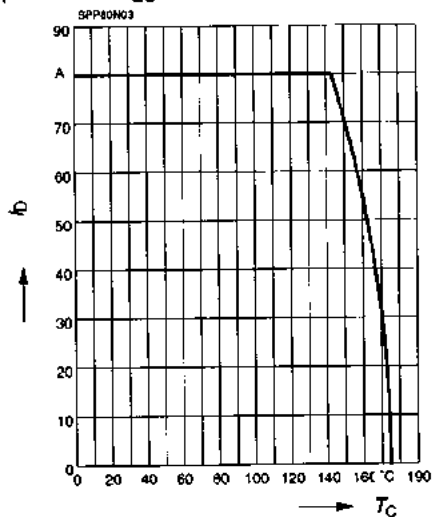

Safe operating area

$I_D = f(V_{DS})$

parameter: $D = 0, T_C = 25\text{ °C}$

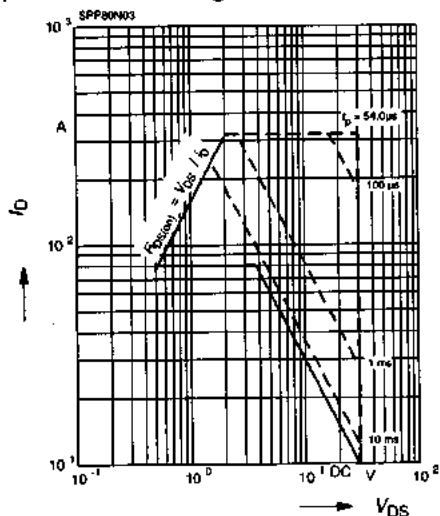

Transient thermal impedance

$Z_{thJC} = f(t_p)$

parameter: $D = t_p/T$

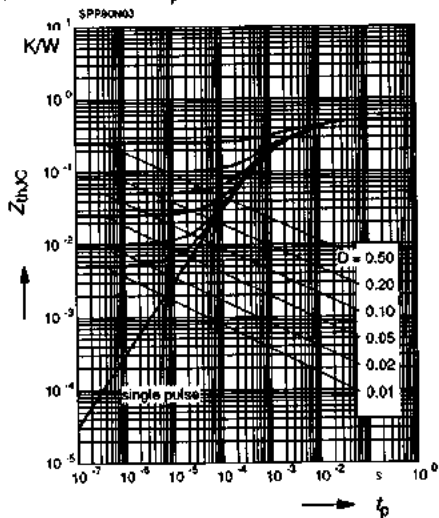

Typ. output characteristics

$$I_D = f(V_{DS})$$

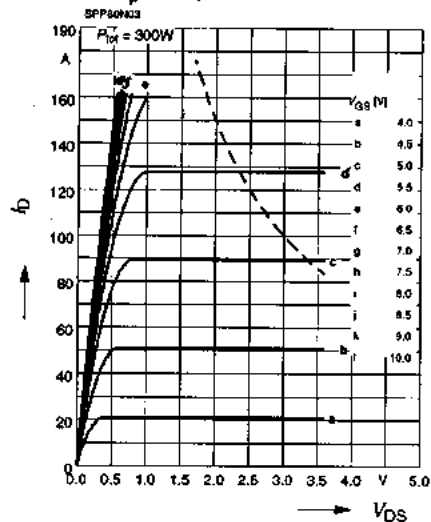
 parameter: $t_p = 80 \mu s$

Typ. drain-source-on-resistance

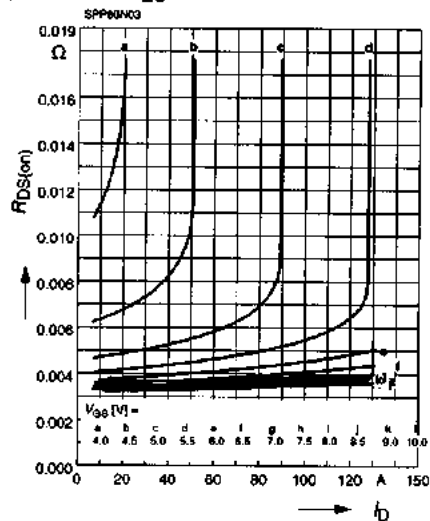
$$R_{DS(on)} = f(I_D)$$

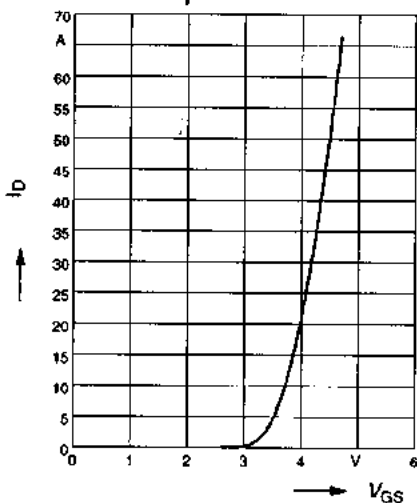
 parameter: V_{GS}

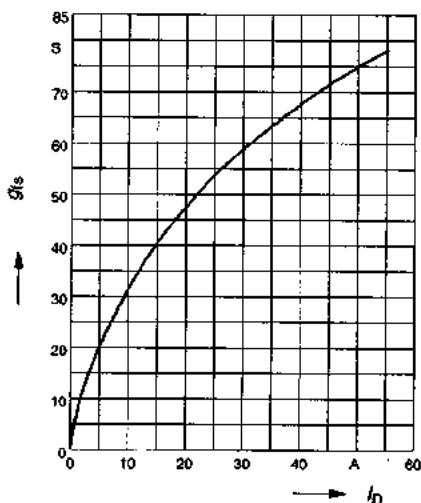
Typ. transfer characteristics $I_D = f(V_{GS})$

 parameter: $t_p = 80 \mu s$
 $V_{DS} \geq 2 \times I_D \times R_{DS(on)} \text{ max}$

Typ. forward transconductance
 $g_{fs} = f(I_D); T_j = 25^\circ C$

 parameter: g_{fs}

Drain-source on-resistance

$$R_{DS(on)} = f(T_j)$$

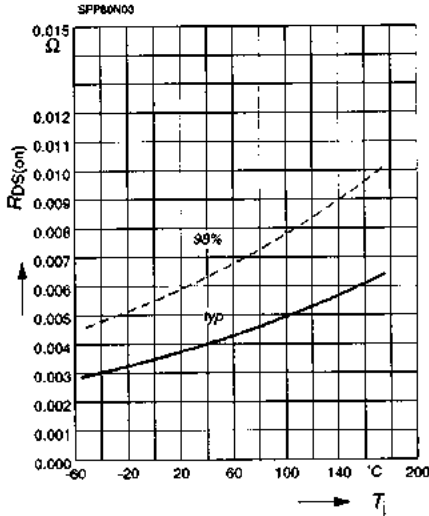
parameter : $I_D = 80 \text{ A}$, $V_{GS} = 10 \text{ V}$



Gate threshold voltage

$$V_{GS(th)} = f(T_j)$$

parameter : $V_{GS} = V_{DS}$, $I_D = 240 \mu\text{A}$

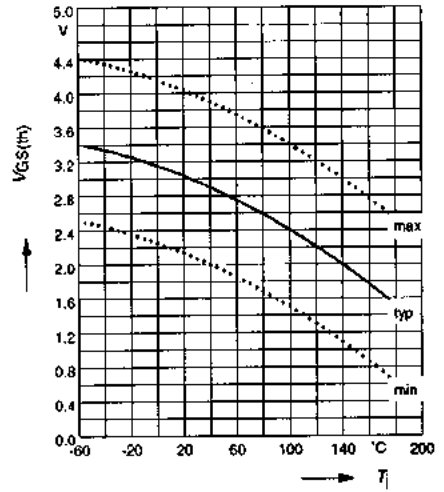

Typ. capacitances

$$C = f(V_{DS})$$

parameter: $V_{GS} = 0 \text{ V}$, $f = 1 \text{ MHz}$

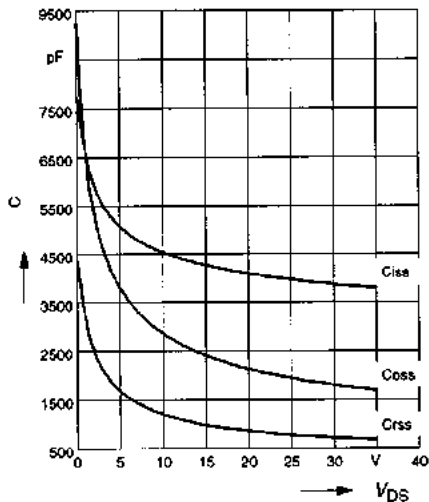

Forward characteristics of reverse diode

$$I_F = f(V_{SD})$$

parameter: T_j , $t_p = 80 \mu\text{s}$

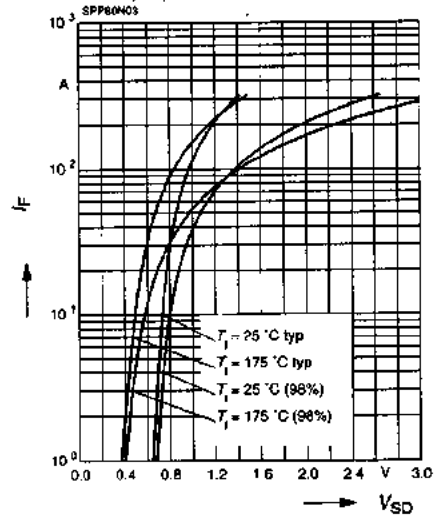

Avalanche Energy $E_{AS} = f(T_j)$

parameter: $I_D = 80\text{ A}$, $V_{DD} = 25\text{ V}$

$R_{GS} = 25\ \Omega$

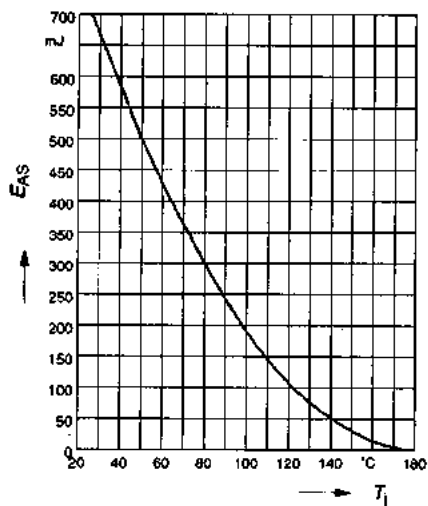

Typ. gate charge $V_{GS} = f(Q_{Gate})$

parameter: $I_{D\text{ puls}} = 80\text{ A}$

$I_{D\text{ puls}} = 80\text{ A}$

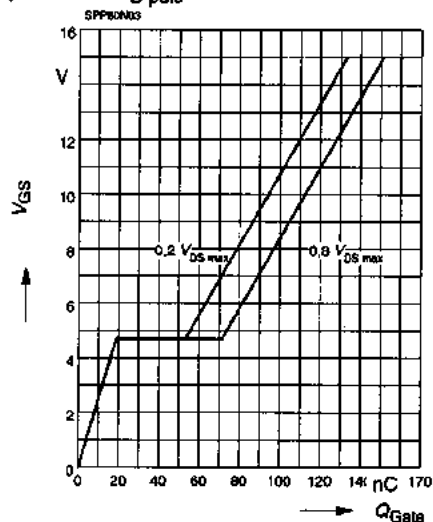

Drain-source breakdown voltage $V_{(BR)DSS} = f(T_j)$

$V_{(BR)DSS} = f(T_j)$

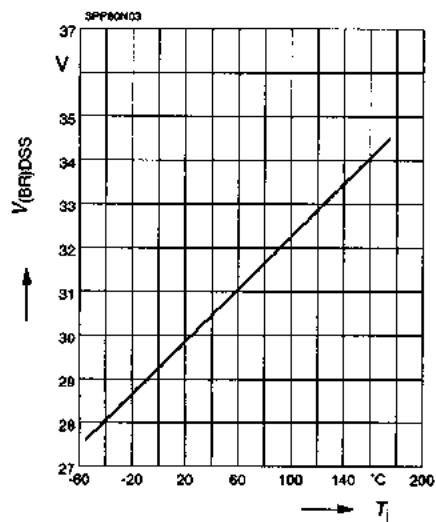

Gehäusemaßbilder

(Maße in mm, wenn nicht anders angegeben)

Package Outlines

(Dimensions in mm, unless otherwise specified)

P-DSO-8-6-7

Gewicht etwa 0.15 g

Approx. weight 0.15 g

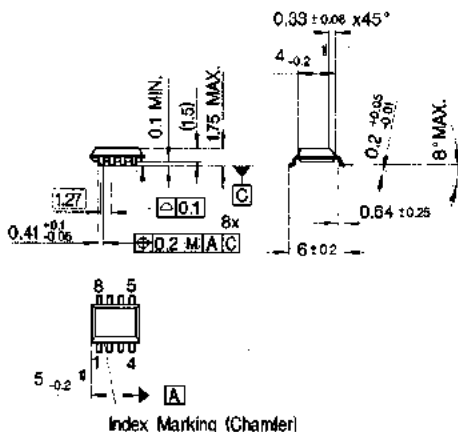

1) Does not include plastic or metal protrusion of 0.15 max. per side

Bild 16

Figure 16

P-TO218-AA (P-TO218-2-1)

Gewicht etwa 4.9 g

Approx. weight 4.9 g

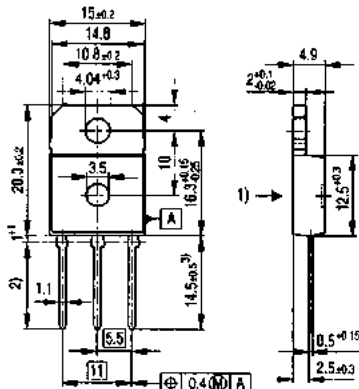
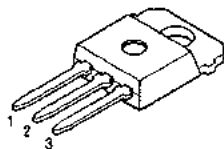

- 1) Punch direction, burr max. 0.04
- 2) Dip tinning
- 3) Max. 15.5 by dip tinning press burr max. 0.05 radii not dimensioned max. 0.2

OPT0218A

Bild 17

Figure 17

P-TO220-3-1

Gewicht etwa 1.8 g
Approx. weight 1.8 g

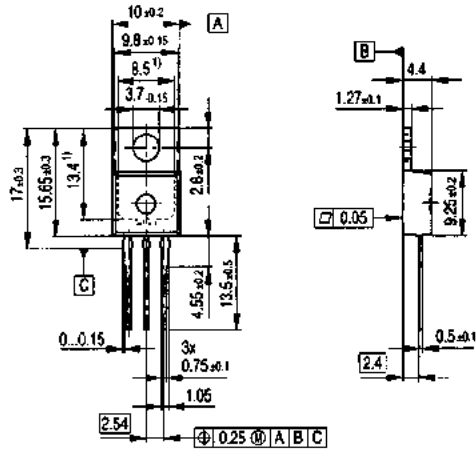
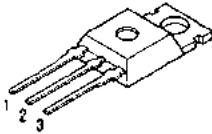

¹⁾ Typical

All metal surfaces tin plated, except area of cut.

GPT0555

Bild 18

Figure 18

P-TO251-3-1

Gewicht etwa 2.0 g
Approx. weight 2.0 g

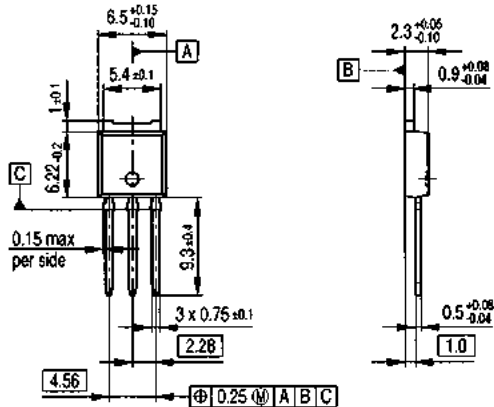
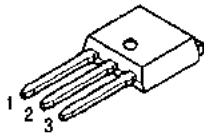

All metal surfaces tin plated, except area of cut.

GPT06050

Bild 19

Figure 19

P-TO252-3-1

Gewicht etwa 0.38 g
Approx. weight 0.38 g

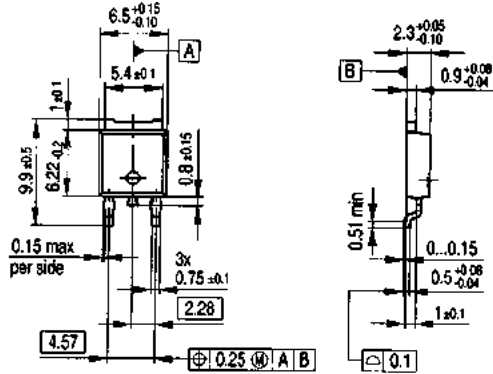
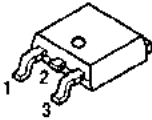

All metal surfaces tin plated, except area of cut.

GPT09051

Bild 20

Figure 20

P-TO262-3-1/1²PAK

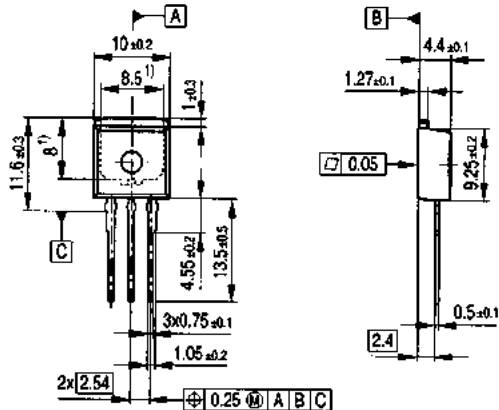
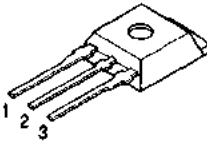

¹⁾ Typical

Metal surface min. X = 7.25, Y = 7.35

All metal surfaces tin plated, except area of cut.

GPT00244

Bild 21

Figure 21

P-TQ263-3-2/D²PAK

Gewicht etwa 1.38 g
Approx. weight 1.38 g

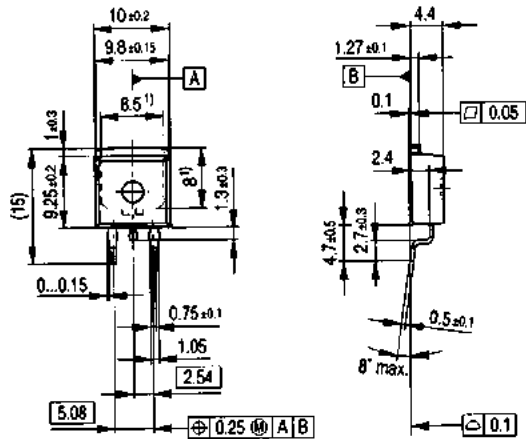
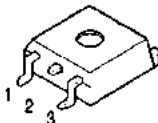

¹⁾ Typical

All metal surfaces tin plated, except area of cut.

GFT09085

Bild 22

Figure 22

SOT-23 (P-SOT23-3-1)

Gewicht etwa 0.01 g
Approx. weight 0.01 g

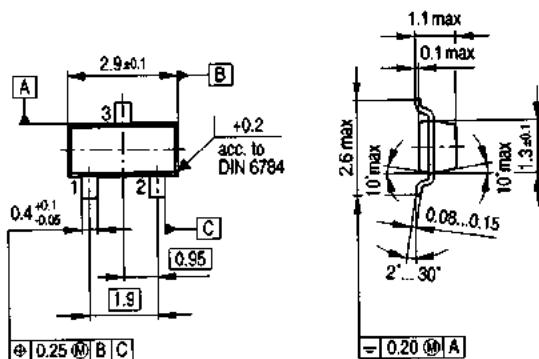
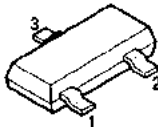

GPS06557

Bild 23

Figure 23

SOT-89

Gewicht etwa 0.01 g
Approx. weight 0.01 g

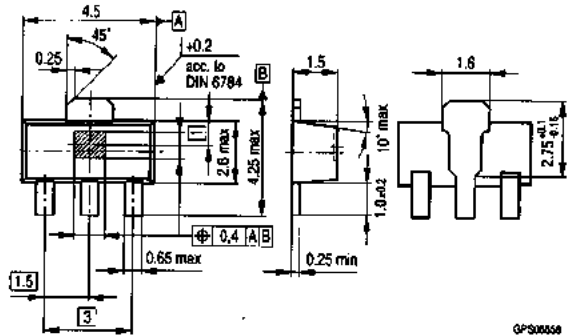
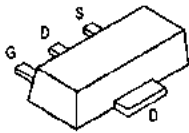

GPS00050

Bild 24

Figure 24

SOT-223 (P-SOT223-4-1)

Gewicht etwa 0.15 g
Approx. weight 0.15 g

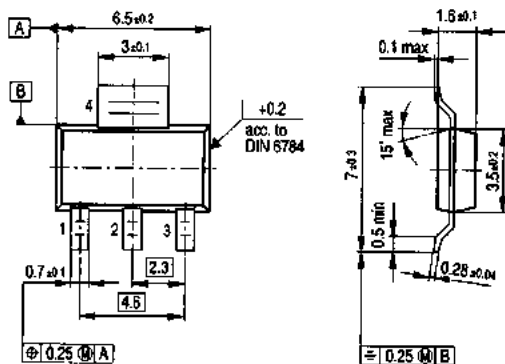
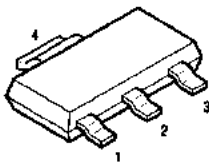

GPS00500

Bild 25

Figure 25

TO-92

Gewicht etwa 0.23 g

Approx. weight 0.23 g



Bild 26

Figure 26

TO-92-E6288

Gewicht etwa 0.23 g

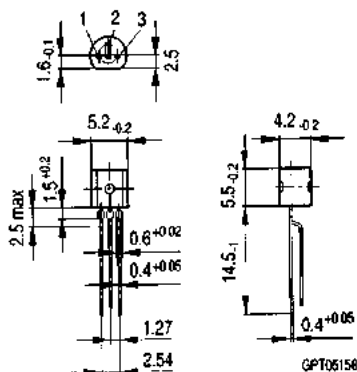
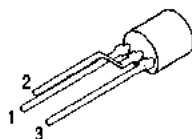
Approx. weight 0.23 g



Bild 27

Figure 27

Sorts of Packing

Package outlines for tubes, trays etc. are contained in our Data Book "Package Information".

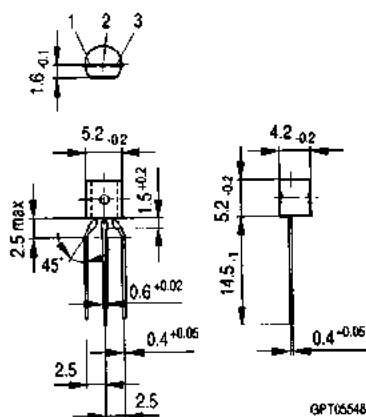
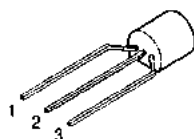
SMD = Surface Mounted Device