

MOS FIELD EFFECT POWER TRANSISTORS

2SK2134, 2SK2134-Z

SWITCHING

N-CHANNEL POWER MOS FET

INDUSTRIAL USE

DESCRIPTION

The 2SK2134, 2SK2134-Z are N-channel Power MOS Field Effect Transistors designed for high voltage switching applications.

FEATURES

- Low On-state Resistance
 $R_{DS(on)} = 0.4 \Omega \text{ MAX. (} V_{GS} = 10 \text{ V, } I_D = 7.0 \text{ A)}$
- Low C_{iss} $C_{iss} = 500 \text{ pF TYP.}$
- High Avalanche Capability Ratings

QUALITY GRADE

Standard

Please refer to "Quality grade on NEC Semiconductor Devices" (Document number IEI-1209) published by NEC Corporation to know the specification of quality grade on the devices and its recommended applications.

ABSOLUTE MAXIMUM RATINGS

Drain to Source Voltage	V_{DSS}	200	V
Gate to Source Voltage	V_{GSS}	± 30	V
Drain Current (DC)	$I_{D(DC)}$	± 13	A
Drain Current (pulse)	$I_{D(pulse)}$ *	± 39	A
Single Avalanche Current**	I_{AS}	13	A
Single Avalanche Energy**	E_{AS}	33.8	mJ
Total Power Dissipation ($T_a = 25^\circ\text{C}$)	P_{T1}	1.5	W
Total Power Dissipation ($T_c = 25^\circ\text{C}$)	P_{T2}	70	W
Storage Temperature	T_{stg}	-55 to +150	$^\circ\text{C}$
Channel Temperature	T_{ch}	150	$^\circ\text{C}$

* $PW \leq 10 \mu\text{s}$, Duty Cycle $\leq 1\%$

** Starting $T_{ch} = 25^\circ\text{C}$, $R_G = 25 \Omega$, $V_{GS} = 20 \text{ V} \rightarrow 0$

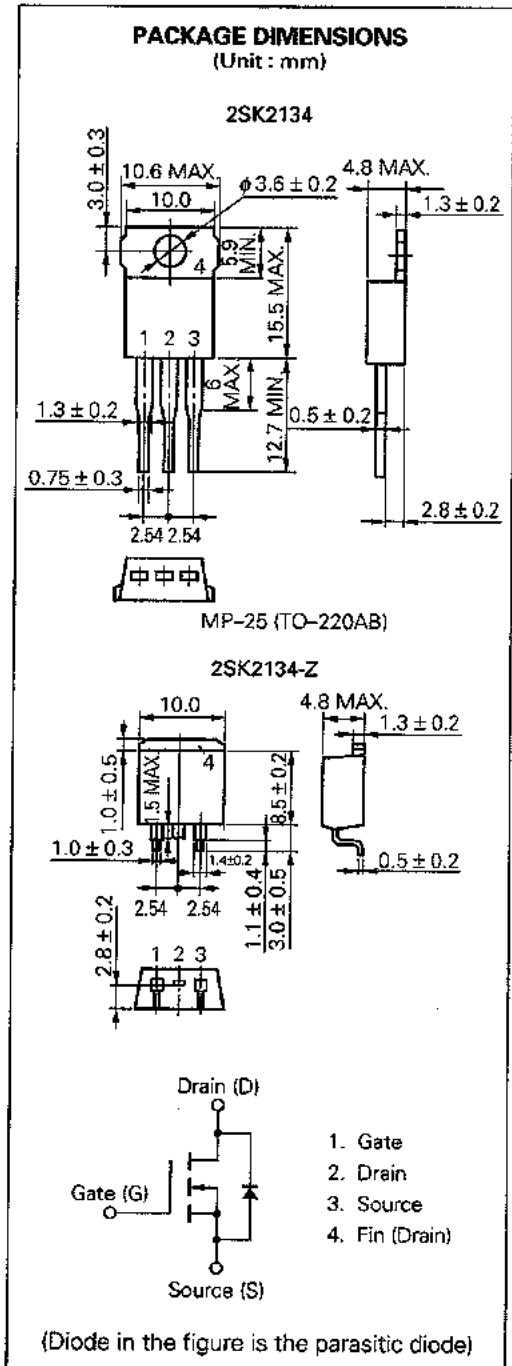

ELECTRICAL CHARACTERISTICS (T_a = 25 °C)

CHARACTERISTIC	SYMBOL	MIN.	TYP.	MAX.	UNIT	TEST CONDITIONS
Drain to Source On-state Resistance	R _{DS(on)}		0.3	0.4	Ω	V _{GS} = 10 V, I _D = 7.0 A
Gate to Source Cutoff Voltage	V _{GS(off)}	2.0		4.0	V	V _{DS} = 10 V, I _D = 1 mA
Forward Transfer Admittance	y _{fs}	2.0			S	V _{DS} = 10 V, I _D = 7.0 A
Drain Leakage Current	I _{DSS}			100	μA	V _{DS} = 200 V, V _{GS} = 0
Gate to Source Leakage Current	I _{GSS}			±100	nA	V _{GS} = ±30 V, V _{DS} = 0
Input Capacitance	C _{iss}		500		pF	V _{DS} = 10 V
Output Capacitance	C _{oss}		230		pF	V _{GS} = 0
Reverse Transfer Capacitance	C _{res}		60		pF	f = 1 MHz
Turn-On Delay Time	t _{d(on)}		12		ns	V _{GS} = 10 V
Rise Time	t _r		45		ns	V _{DD} = 100 V
Turn-Off Delay Time	t _{d(off)}		35		ns	I _D = 7.0 A, R _θ = 10 Ω
Fall Time	t _f		12		ns	R _L = 14.3 Ω
Total Gate Charge	Q _G		15		nC	V _{GS} = -10 V
Gate to Source Charge	Q _{GS}		5.0		nC	I _D = 13 A
Gate to Drain Charge	Q _{GD}		8.0		nC	V _{DD} = 160 V
Diode Forward Voltage	V _{FIS-DI}		1.0		V	I _F = 13 A, V _{GS} = 0
Reverse Recovery Time	t _{rr}		200		ns	I _F = 13 A
Reverse Recovery Charge	Q _{rr}		0.6		μC	di/dt = 50 A/μs

Test Circuit 1 : Avalanche Capability

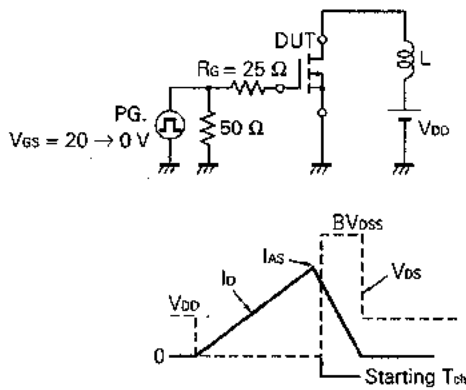

Test Circuit 2 : Switching Time

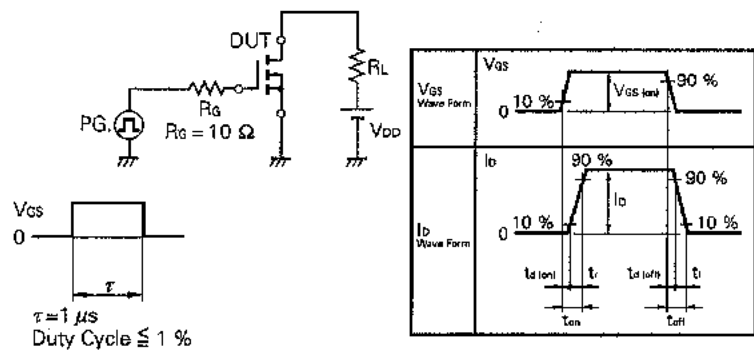

Test Circuit 3 : Gate Charge

