

MOS FIELD EFFECT TRANSISTOR
2SK2485

SWITCHING
 N-CHANNEL POWER MOS FET
 INDUSTRIAL USE

DESCRIPTION

The 2SK2485 is N-Channel MOS Field Effect Transistor designed for high voltage switching applications.

FEATURES

- Low On-Resistance
 $R_{DS(on)} = 2.8 \Omega$ ($V_{GS} = 10 V, I_D = 3.0 A$)
- Low C_{iss} $C_{iss} = 1\ 200\ pF$ TYP.
- High Avalanche Capability Ratings

ABSOLUTE MAXIMUM RATINGS ($T_A = 25\ ^\circ C$)

Drain to Source Voltage	V_{DSS}	900	V
Gate to Source Voltage	V_{GSS}	± 30	V
Drain Current (DC)	$I_D(DC)$	± 6.0	A
Drain Current (pulse)*	$I_D(pulse)$	± 12	A
Total Power Dissipation ($T_c = 25\ ^\circ C$)	P_{T1}	100	W
Total Power Dissipation ($T_A = 25\ ^\circ C$)	P_{T2}	3.0	W
Channel Temperature	T_{ch}	150	$^\circ C$
Storage Temperature	T_{stg}	-55 to +150	$^\circ C$
Single Avalanche Current**	I_{AS}	6.0	A
Single Avalanche Energy**	E_{AS}	42.3	mJ

* $PW \leq 10\ \mu s, Duty\ Cycle \leq 1\ %$

** Starting $T_{ch} = 25\ ^\circ C, R_G = 25\ \Omega, V_{GS} = 20\ V \rightarrow 0$

PACKAGE DIMENSIONS
 (in millimeter)

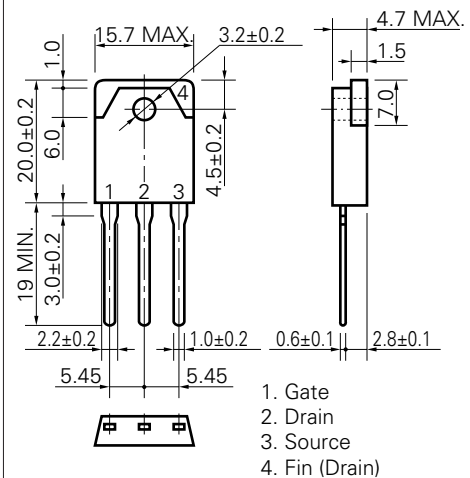

MP-88

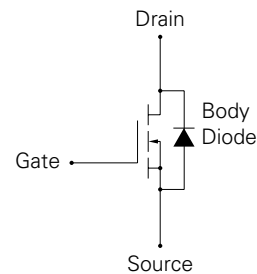

ELECTRICAL CHARACTERISTICS (T_A = 25 °C)

CHARACTERISTIC	SYMBOL	MIN.	TYP.	MAX.	UNIT	TEST CONDITIONS
Drain to Source On-Resistance	R _{DS(on)}		2.2	2.8	Ω	V _{GS} = 10 V, I _D = 3.0 A
Gate to Source Cutoff Voltage	V _{GS(off)}	2.5		3.5	V	V _{DS} = 10 V, I _D = 1 mA
Forward Transfer Admittance	y _{fs}	2.0			S	V _{DS} = 10 V, I _D = 3.0 A
Drain Leakage Current	I _{DSS}			100	μA	V _{DS} = V _{DSS} , V _{GS} = 0
Gate to Source Leakage Current	I _{GSS}			±100	nA	V _{GS} = ±30 V, V _{DS} = 0
Input Capacitance	C _{iss}		1200		pF	V _{DS} = 10 V
Output Capacitance	C _{oss}		170		pF	V _{GS} = 0
Reverse Transfer Capacitance	C _{rss}		30		pF	f = 1 MHz
Turn-On Delay Time	t _{d(on)}		20		ns	I _D = 3.0 A
Rise Time	t _r		10		ns	V _{GS} = 10 V
Turn-Off Delay Time	t _{d(off)}		70		ns	V _{DD} = 150 V
Fall Time	t _f		15		ns	R _G = 10 Ω R _L = 50 Ω
Total Gate Charge	Q _G		40		nC	I _D = 6.0 A
Gate to Source Charge	Q _{GS}		7		nC	V _{DD} = 450 V
Gate to Drain Charge	Q _{GD}		17		nC	V _{GS} = 10 V
Body Diode Forward Voltage	V _{F(S-D)}		1.0		V	I _F = 6.0 A, V _{GS} = 0
Reverse Recovery Time	t _{rr}		740		ns	I _F = 6.0 A, V _{GS} = 0
Reverse Recovery Charge	Q _{rr}		4.0		μC	di/dt = 50 A/μs

Test Circuit 1 Avalanche Capability

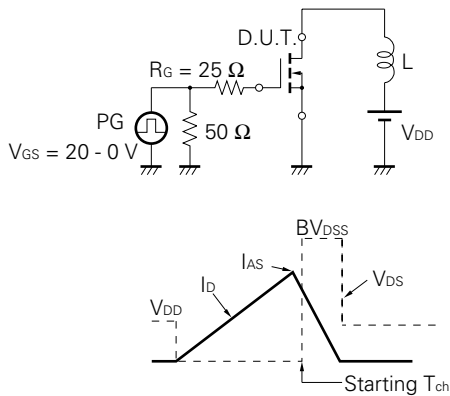

Test Circuit 2 Switching Time

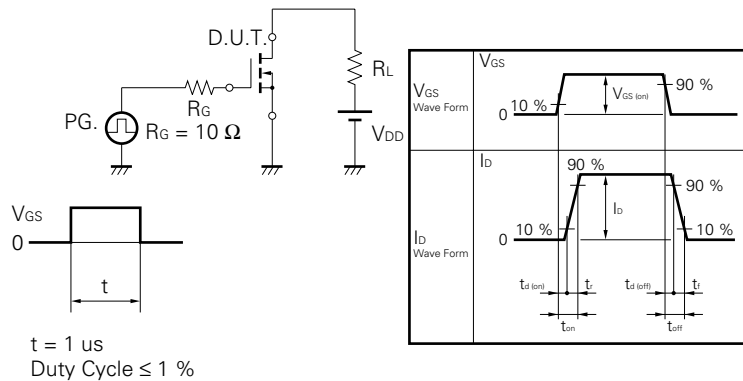

Test Circuit 3 Gate Charge

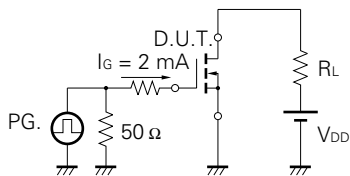

The application circuits and their parameters are for references only and are not intended for use in actual design-in's.