

N-CHANNEL SILICON POWER MOS-FET

F-I SERIES

Features

- High speed switching
- Low on-resistance
- No secondary breakdown
- Low driving power
- High voltage
- Avalanche-proof

Applications

- Switching regulators
- UPS
- DC-DC converters
- General purpose power amplifier

Outline Drawings

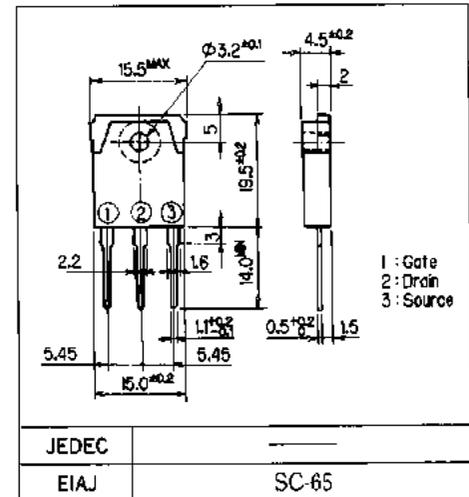

Max. Ratings and Characteristics

Absolute Maximum Ratings(Tc=25°C)

Items	Symbols	Ratings	Units
Drain-source voltage	V_{DSS}	900	V
Continuous drain current	I_D	5	A
Pulsed drain current	$I_{D(puls)}$	20	A
Continuous reverse drain current	I_{DR}	5	A
Gate-source peak voltage	V_{GSS}	± 20	V
Max. power dissipation	P_D	125	W
Operating and storage temperature range	T_{stg}	-55 ~ +150	°C

Equivalent Circuit Schematic

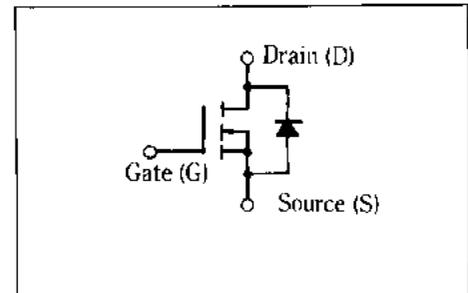

Electrical Characteristics(Tc=25°C)

Items	Symbols	Test Conditions	Min.	Typ.	Max.	Units
Drain-source breakdown voltage	$V_{(BR)DSS}$	$I_D = 1mA$ $V_{GS} = 0V$	900			V
Gate threshold voltage	$V_{GS(th)}$	$I_D = 10mA$ $V_{DS} = V_{GS}$	2.1	3.0	4.0	V
Zero gate voltage drain current	I_{DSS}	$V_{DS} = 900V$ $V_{GS} = 0V$ $T_{cb} = 25^\circ C$		10	500	μA
Gate-source leakage current	I_{GSS}	$V_{GS} = \pm 20V$ $V_{DS} = 0V$		10	100	nA
Drain-source on-state resistance	$R_{DS(on)}$	$I_D = 2.5A$ $V_{GS} = 10V$		2.0	2.5	Ω
Forward transconductance	g_{fs}	$I_D = 2.5A$ $V_{DS} = 25V$	3.0	6.0		S
Input capacitance	C_{iss}	$V_{DS} = 25V$		1500	2400	pF
Output capacitance	C_{oss}	$V_{GS} = 0V$		150	240	
Reverse transfer capacitance	C_{rss}	$f = 1MHz$		50	80	
Switching time ($t_{off} = t_{(orm)} + t_r$)	t_{on}	$V_{CC} = 30V$ $R_G = 50\Omega$		110	170	ns
	$t_{d(off)}$	$I_D = 2.4A$		300	450	
	t_r	$V_{GS} = 10V$		120	180	
Diode forward on-voltage	V_{SD}	$I_F = 2 \times I_{DR}$ $V_{GS} = 0V$ $T_{cb} = 25^\circ C$		1.0	1.5	V
Reverse recovery time	t_{rr}	$I_F = I_{DR}$ $di/dt = 100A/\mu s$ $T_{cb} = 25^\circ C$		900		ns

Thermal Characteristics

Items	Symbols	Test Conditions	Min.	Typ.	Max.	Units
Thermal Resistance	$R_{th(ch-a)}$	channel to air			35	°C/W
	$R_{th(ch-c)}$	channel to case			1.0	°C/W