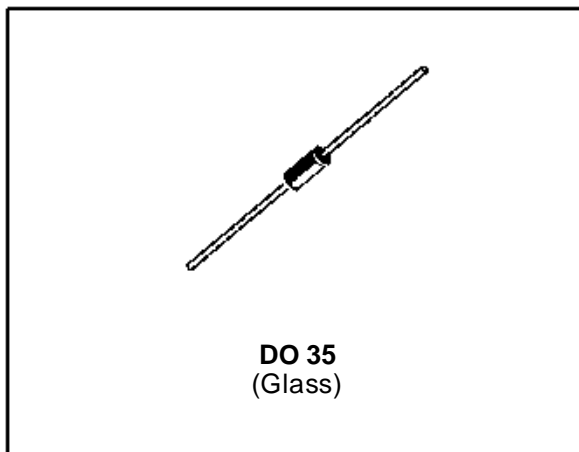

**TRIGGER DIODES**
**FEATURES**

- $V_{BO}$  : 32V / 34V / 40V VERSIONS
- LOW BREAKOVER CURRENT

**DESCRIPTION**

High reliability glass passivation insuring parameter stability and protection against junction contamination.

**ABSOLUTE RATINGS** (limiting values)

Symbol	Parameter		Value	Unit
P	Power dissipation on printed circuit (L = 10 mm)	Ta = 65 °C	150	mW
I <sub>TRM</sub>	Repetitive peak on-state current	tp = 20 μs F = 100 Hz	2	A
T <sub>stg</sub> T <sub>j</sub>	Storage and operating junction temperature range		- 40 to + 125 - 40 to + 125	°C °C

**THERMAL RESISTANCES**

Symbol	Parameter	Value	Unit
R <sub>th (j-a)</sub>	Junction to ambient	400	°C/W
R <sub>th (j-l)</sub>	Junction-leads	150	°C/W

**DB3 / DB4 / DC34**

**ELECTRICAL CHARACTERISTICS** (Tj = 25°C)

Symbol	Parameter	Test Conditions		Value			Unit
				DB3	DC34	DB4	
V <sub>BO</sub>	Breakover voltage *	C = 22nF ** see diagram 1	MIN	28	30	35	V
			TYP	32	34	40	
			MAX	36	38	45	
[ +V <sub>BO</sub>   -   -V <sub>BO</sub>  ]	Breakover voltage symmetry	C = 22nF ** see diagram 1	MAX	± 3			V
ΔV ± I	Dynamic breakover voltage *	ΔI = [I <sub>BO</sub> to I <sub>F</sub> =10mA] see diagram 1	MIN	5			V
V <sub>O</sub>	Output voltage *	see diagram 2	MIN	5			V
I <sub>BO</sub>	Breakover current *	C = 22nF **	MAX	100	50	100	μA
t <sub>r</sub>	Rise time *	see diagram 3	TYP	1.5			μs
I <sub>B</sub>	Leakage current *	V <sub>B</sub> = 0.5 V <sub>BO</sub> max see diagram 1	MAX	10			μA

\* Electrical characteristic applicable in both forward and reverse directions.

\*\* Connected in parallel with the devices.

**DIAGRAM 1 : Current-voltage characteristics**

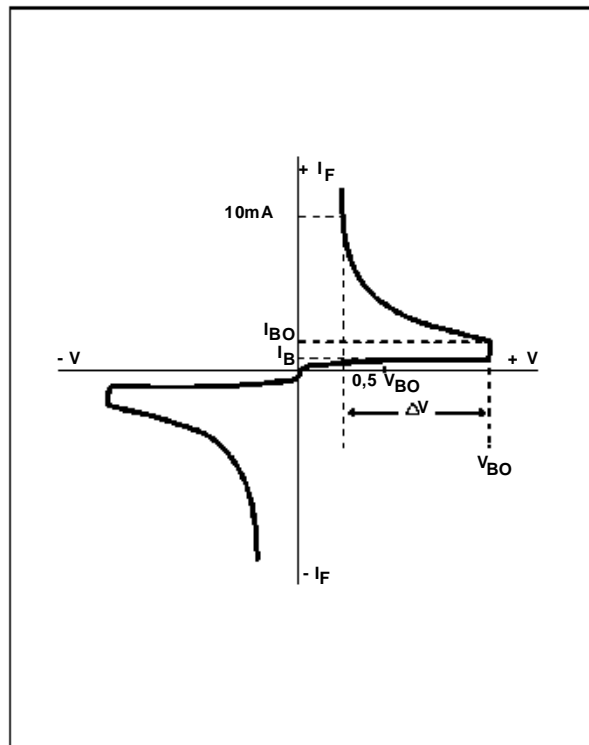

**DIAGRAM 2 : Test circuit for output voltage**

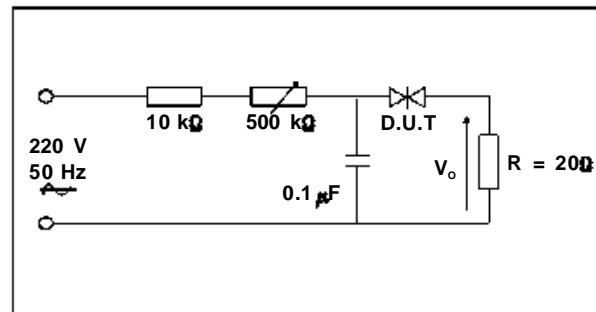

**DIAGRAM 3 : Test circuit see diagram 2.  
Adjust R for I<sub>p</sub>=0.5A**

