



MASTER INSTRUMENT CORPORATION

SINGLE-PHASE BRIDGE RECTIFIER BR1505 THRU BR1510

VOLTAGE RANGE 50 to 1000 Volts
CURRENT 15 Amperes

FEATURES

- l Low cost
- l This series is UL recognized under component index, file number E127707
- l High forward surge current capability
- l Integrally molded heatsink provide very low thermal resistance
- l High isolation voltage from case to lugs
- l High temperature soldering guaranteed: 260°C/10 second, at 5 lbs. (2.3kg) tension.

MECHANICAL DATA

- l Case: Molded plastic body
- l Terminal: Lead solderable per MIL-STD-202E method 208C.
- l Polarity: Polarity symbols molded on case
- l Mounting: Thru hole for #6 screw, 5.0 in.-lbs torque max.
- l Weight: 0.20ounce, 5.62 grams

BR-35

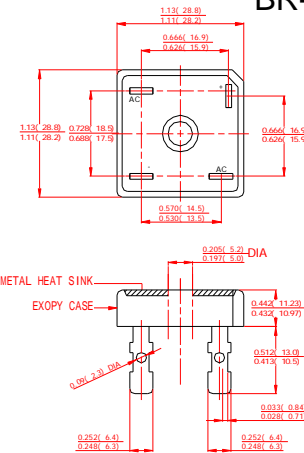

Dimensions in inches and (millimeters)

MAXIMUM RATINGS AND ELECTRICAL CHARACTERISTICS

Ratings at 25°C ambient temperature unless otherwise specified.
Single phase, half wave, 60Hz, resistive or inductive load.
For capacitive load derate current by 20%.

	SYMBOLS	BR1505	BR151	BR152	BR154	BR156	BR158	BR1510	UNITS	
Maximum Repetitive Peak Reverse Voltage	V_{RRM}	50	100	200	400	600	800	1000	Volts	
Maximum RMS Voltage	V_{RMS}	35	70	140	280	420	560	700	Volts	
Maximum DC Blocking Voltage	V_{DC}	50	100	200	400	600	800	1000	Volts	
Maximum Average Forward Rectified Output Current, at $T_C=55^\circ\text{C}$ (Note 1, 2)	$I_{(AV)}$	15							Amps	
Peak Forward Surge Current 8.3ms single half sine-wave superimposed on rated load (JEDEC Method)	I_{FSM}	300							Amps	
Rating for Fusing ($t < 8.3\text{ms}$)	I^2T	373							A^2S	
Maximum Instantaneous Forward Voltage at 7.5A	V_F	1.1							Volts	
Maximum DC Reverse Current at rated DC blocking voltage	I_R	$T_A=25^\circ\text{C}$	10							μAmps
		$T_A=150^\circ\text{C}$	1.0							mAmps
Isolation Voltage from case to leads	V_{ISO}	2500							V_{AC}	
Typical Thermal Resistance (Note 1)	$R_{\theta JC}$	2.0							$^\circ\text{C}/\text{W}$	
Operating Temperature Range	T_J	-55 to +150							$^\circ\text{C}$	
Storage Temperature Range	T_{STG}	-55 to +150							$^\circ\text{C}$	

NOTES:

1. Unit mounted on 5"×4"×3" thick (12.8mm×10.2mm×7.3mm) Al. plate.
2. Bolt down on heat-sink with silicone thermal compound between bridge and mounting surface for maximum heat transfer efficiency with #10 screw.